



US008393342B2

(12) **United States Patent**
Goldberg et al.

(10) **Patent No.:** **US 8,393,342 B2**
(45) **Date of Patent:** **Mar. 12, 2013**

(54) **WALKING CANE**

(75) Inventors: **Ronald M. Goldberg**, North Bergen, NJ
(US); **Joseph Goldberg**, Easton, CT
(US)

(73) Assignee: **Kineticane, LLC**, Greenwood Lake, NY
(US)

2,172,047 A	9/1939	Jacobucci	
2,360,240 A *	10/1944	Kjellstrom	280/819
2,793,680 A *	5/1957	Eben	248/155.1
2,802,479 A	8/1957	Hickman	
3,269,399 A	8/1964	Smith	
3,517,678 A	6/1970	Gilsdorf	
3,995,650 A	12/1976	DiVito	
4,061,347 A	12/1977	Stern et al.	

(Continued)

(*) Notice: Subject to any disclaimer, the term of this patent is extended or adjusted under 35 U.S.C. 154(b) by 0 days.

FOREIGN PATENT DOCUMENTS

JP	2001-145511 A	5/2001
KR	10-2001-0074239 A	8/2001

(Continued)

(21) Appl. No.: **12/894,096**

(22) Filed: **Sep. 29, 2010**

(65) **Prior Publication Data**

US 2011/0073145 A1 Mar. 31, 2011

Related U.S. Application Data

(60) Provisional application No. 61/246,776, filed on Sep. 29, 2009.

(51) **Int. Cl.**
A45B 9/02 (2006.01)

(52) **U.S. Cl.** **135/76; 135/65; 135/82**

(58) **Field of Classification Search** 135/65, 135/72, 76; 16/421, 430, 436, 440, 444, 16/426, 431, DIG. 12, DIG. 19, DIG. 24; 294/57; D3/8

See application file for complete search history.

(56) **References Cited**

U.S. PATENT DOCUMENTS

596,203 A	12/1897	Drake
705,741 A	12/1902	Drew
765,984 A	7/1904	Morris et al.
904,481 A	11/1908	Hood
1,358,643 A	11/1920	Lamming
1,400,600 A	12/1921	Glowacki
1,446,009 A	2/1923	Glowacki

OTHER PUBLICATIONS

Office Actions, Amendments and Notice of Allowance in U.S. Appl. No. 12/893,951.

(Continued)

Primary Examiner — Noah Chandler Hawk
(74) *Attorney, Agent, or Firm* — DuFault Law Firm, P.C.; Dustin R. DuFault

(57) **ABSTRACT**

The present invention includes a walking cane having a handle assembly, a support assembly and foot member. The handle assembly includes first and second generally upright rigid posts. A shaft adaptable for grasping by a user's hand connects to each end of the posts. Pliable mounts dispose between the terminal ends of the shaft and each post. The mounts, biased against the shaft, permit omni-directional movement of the shaft relative to each post. The support assembly connects to the handle assembly and includes three parallel elongated rods spaced apart from one another in a triangular formation. The handle assembly can be adjusted relative to the support assembly by means of two cooperating shims. The foot member connects to the support assembly and contacts the ground. The cane provides a light-weight shaft and a shock absorbing handle assembly to assist in relieving hand, wrist and arm strains.

16 Claims, 6 Drawing Sheets

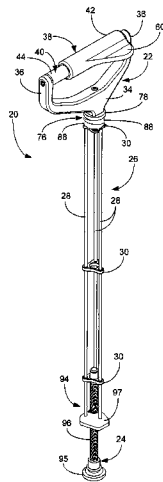

U.S. PATENT DOCUMENTS

4,121,605 A 10/1978 Schmerl
 4,572,227 A 2/1986 Wheeler
 4,609,055 A * 9/1986 Grafstrom et al. 173/162.2
 4,708,154 A 11/1987 Edwards
 4,730,632 A 3/1988 Mace
 4,796,648 A 1/1989 Goulter
 4,958,651 A 9/1990 Najm
 5,168,601 A 12/1992 Liu
 5,301,704 A 4/1994 Brown
 5,699,819 A 12/1997 Simons
 5,711,334 A 1/1998 Roux
 5,720,474 A 2/1998 Sugiyama
 5,901,724 A 5/1999 Andrea et al.
 5,904,167 A 5/1999 Moye
 5,984,359 A * 11/1999 Faiks 280/819
 6,055,998 A 5/2000 Bader
 6,488,042 B2 12/2002 Troyer
 6,668,846 B2 12/2003 Meador
 6,883,530 B2 4/2005 Kawakami
 7,219,679 B2 * 5/2007 Hsu et al. 135/66
 D547,542 S 7/2007 Vellrath
 7,270,138 B2 9/2007 Liao

7,344,320 B2 * 3/2008 Barker et al. 396/419
 7,445,016 B1 11/2008 Ortiz
 7,503,337 B1 3/2009 Morgan et al.
 7,591,275 B2 9/2009 Baker
 2004/0025924 A1 2/2004 Garza, Sr. et al.
 2004/0177873 A1 9/2004 Coakley, Sr.
 2008/0035191 A1 * 2/2008 Baker 135/69
 2008/0173340 A1 7/2008 Robbins

FOREIGN PATENT DOCUMENTS

KR 10-0822716 B1 4/2008
 KR 10-0825189 B1 4/2008
 WO 98-00043 A1 1/1998

OTHER PUBLICATIONS

Notification of Transmittal of the International Search Report and the Written Opinion of the International Searching Authority, or the Declaration, PCT/US2010/050726, Jul. 1, 2011, Korean Patent Office, International Searching Authority.

* cited by examiner

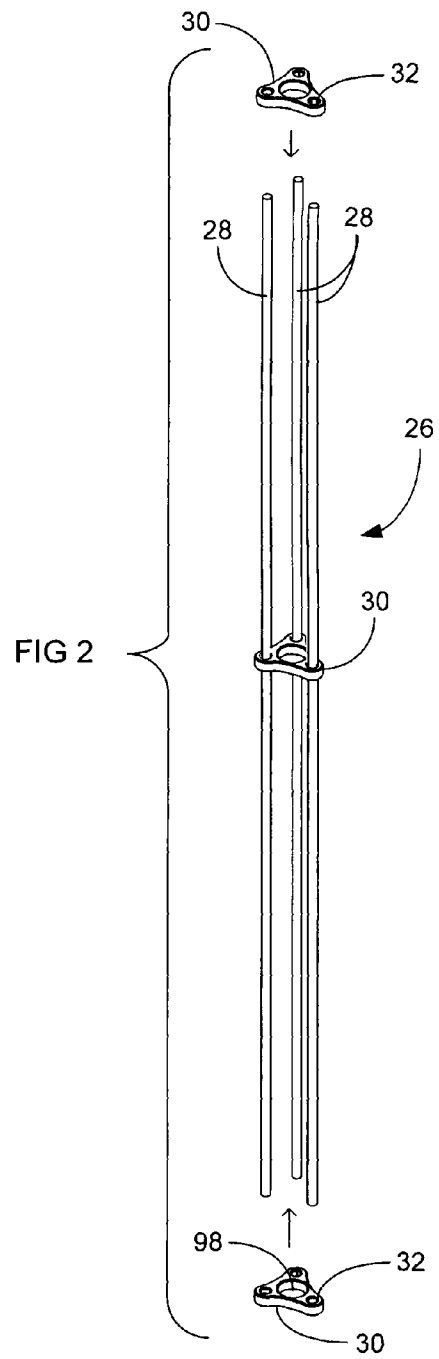
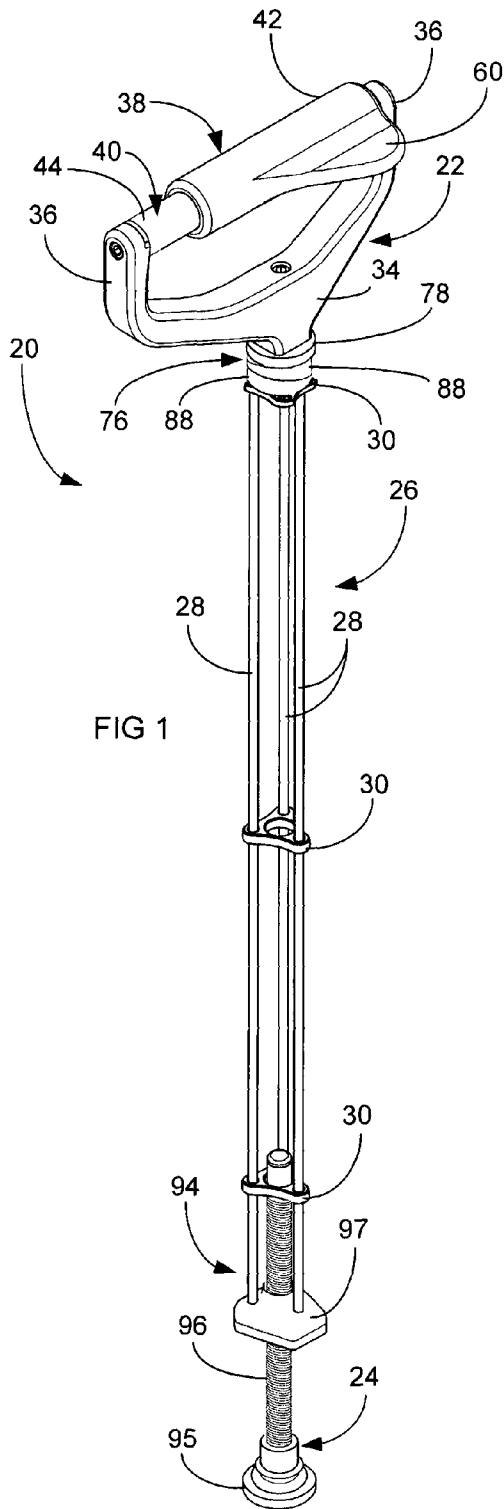

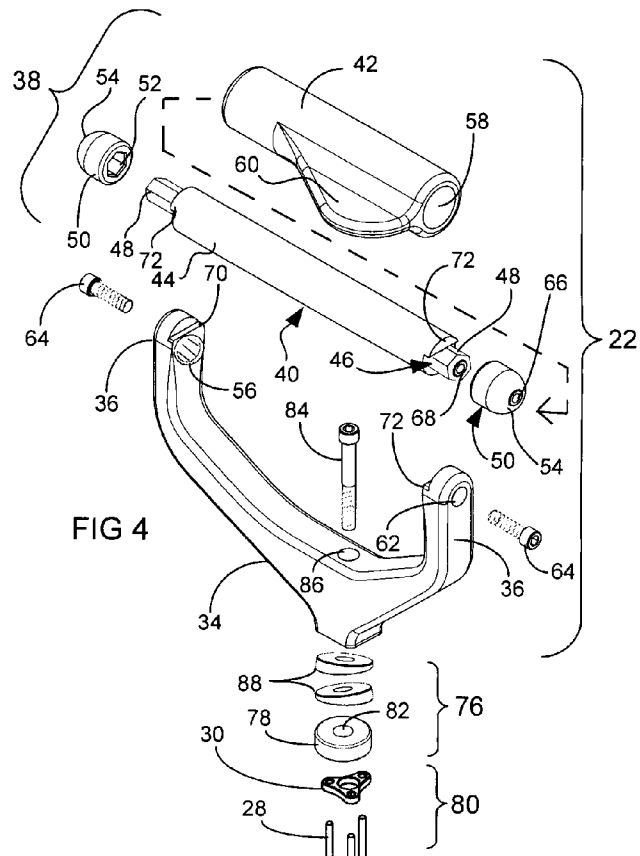
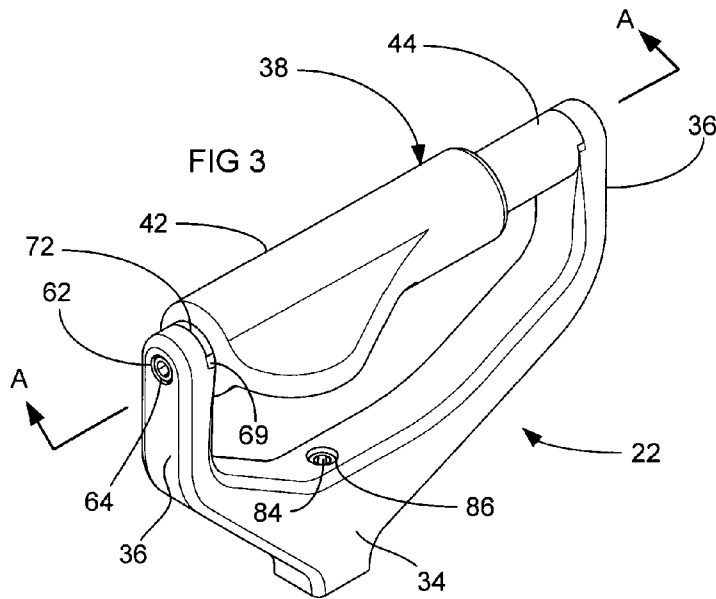
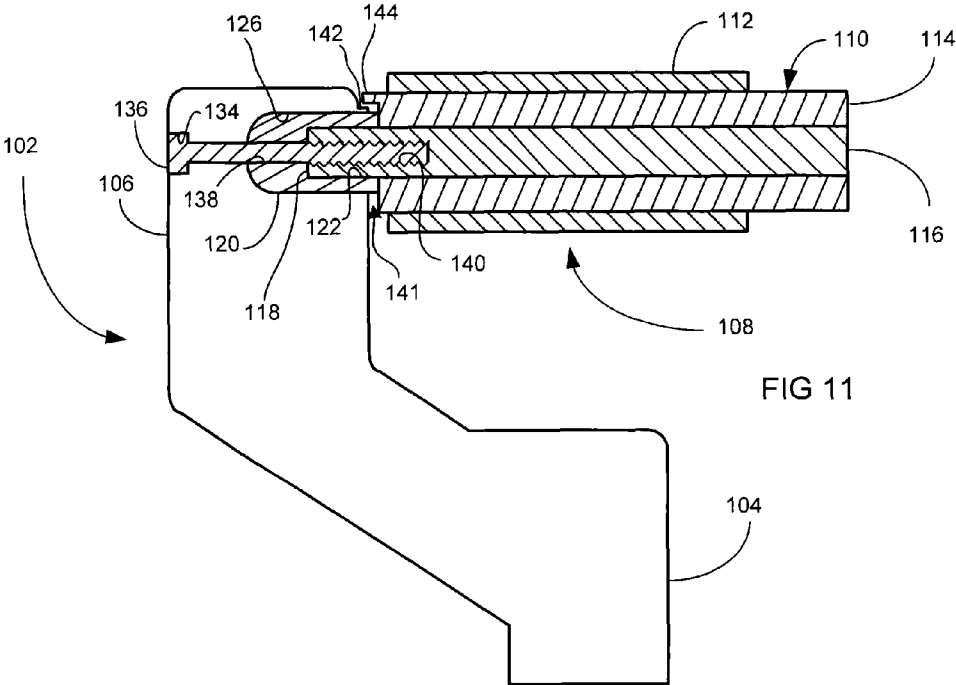
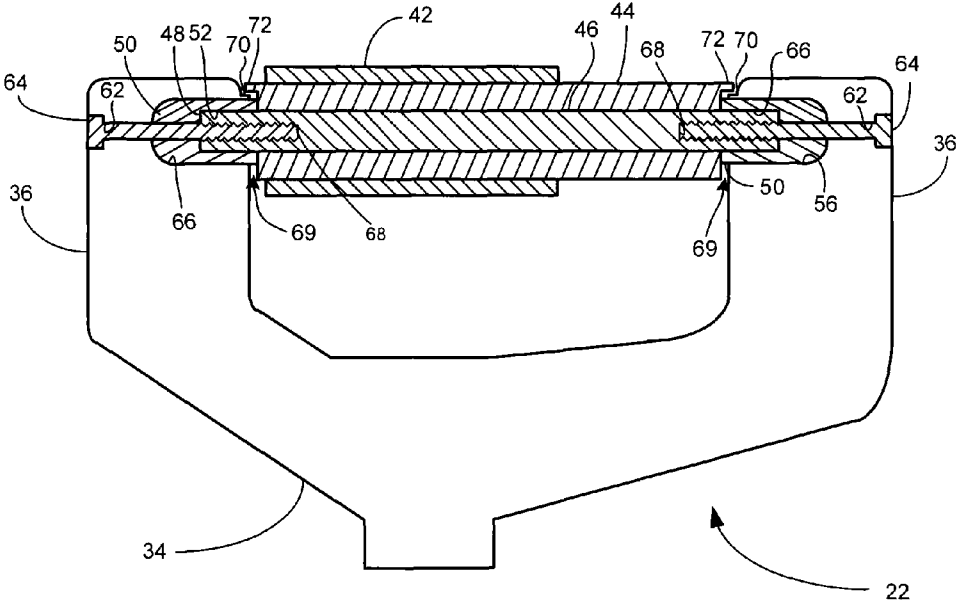
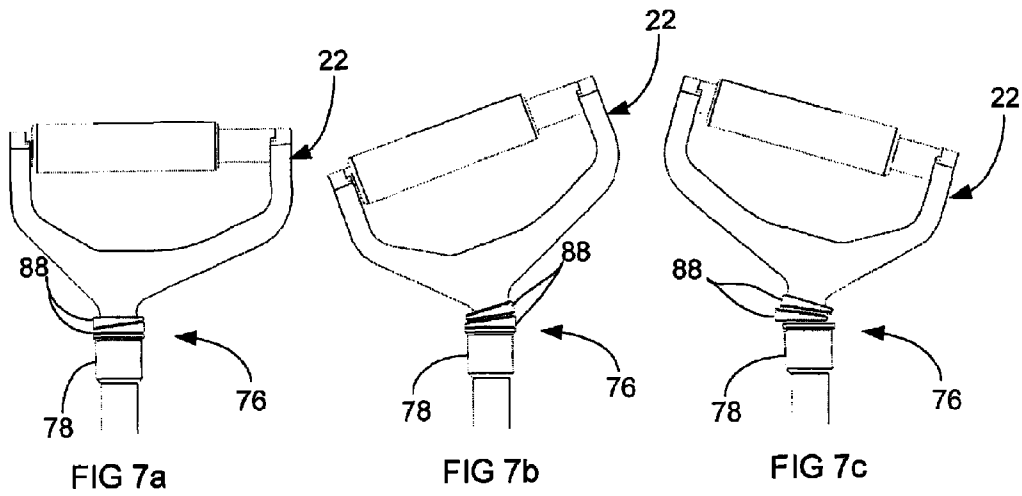
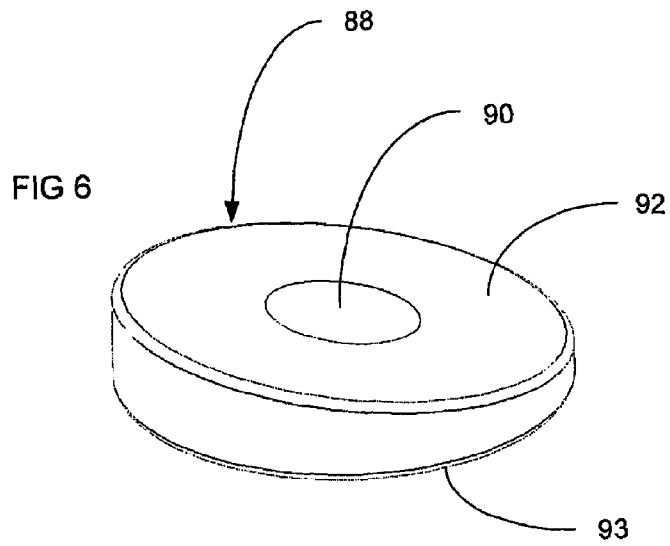
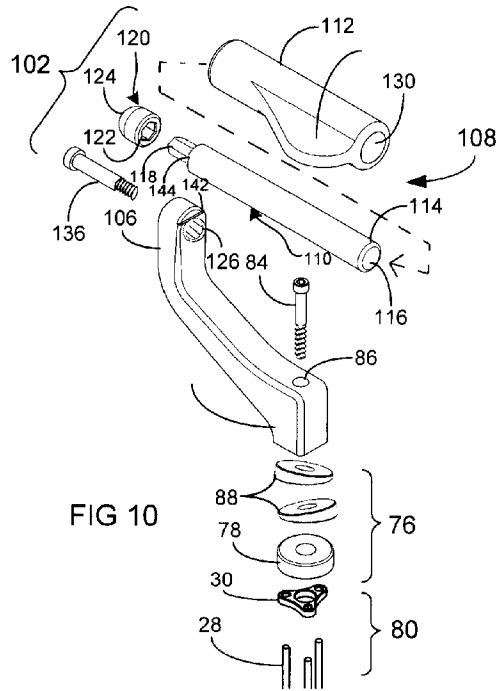
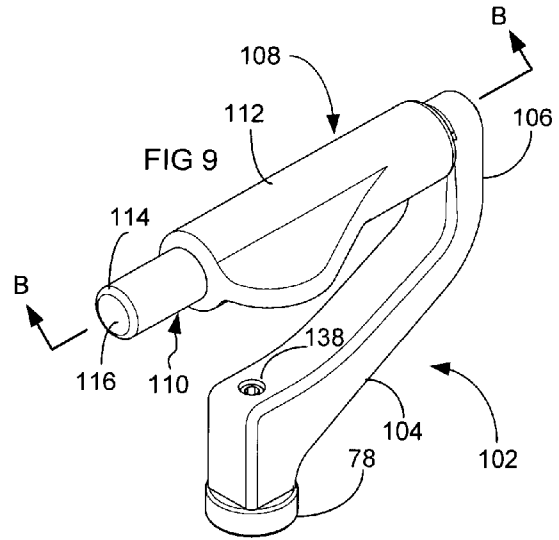
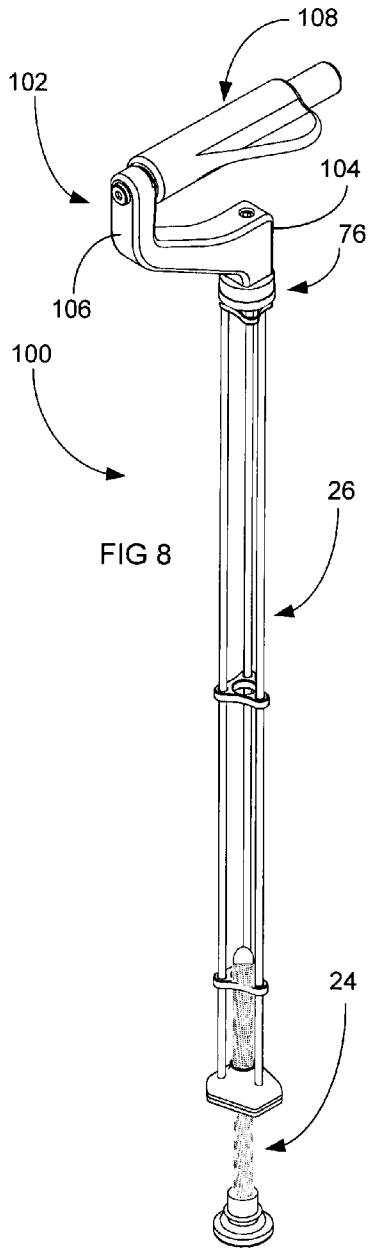
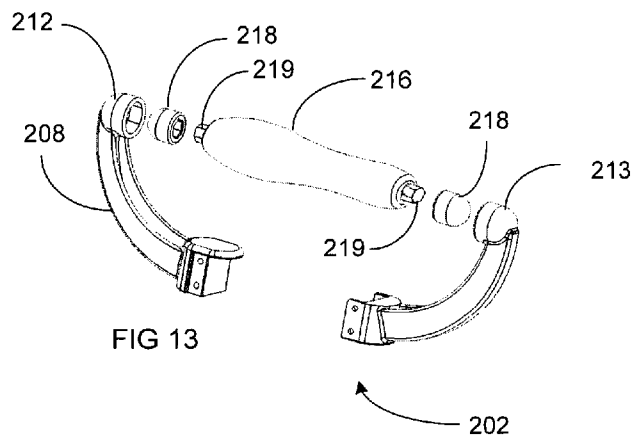
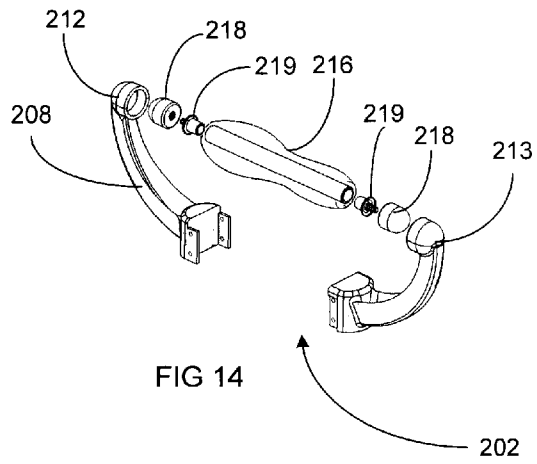
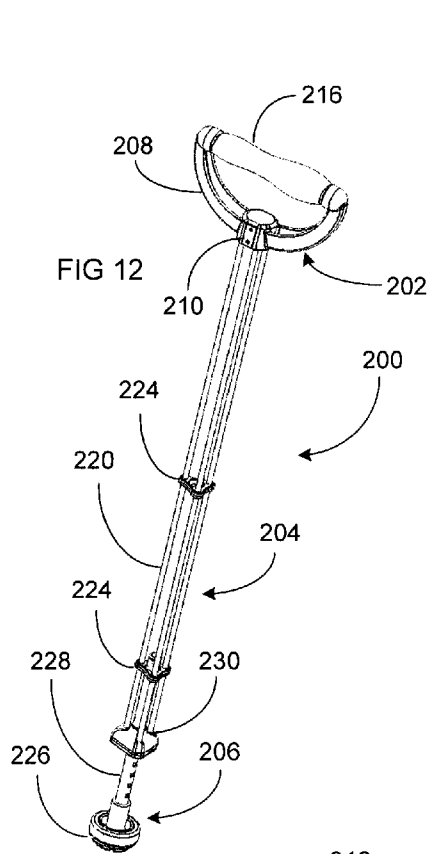

FIG 5









1

WALKING CANE**CROSS-REFERENCE TO RELATED APPLICATION(S)**

This application claims the benefit of U.S. Provisional patent application Ser. No. 61/246,776 entitled WALKING CANE, filed on 29 Sep. 2009, which is hereby incorporated herein by reference.

BACKGROUND OF INVENTION

The present invention is generally directed at ambulatory devices. More particularly, the present invention is directed at a walking aid having improved ergonomics, strategic shock absorption properties, and a lightweight multi-structural shaft.

Walking is an important function in everyday life, even over short distances. Without the aid of ambulatory devices, many individuals have a difficult, if not an impossible, time of moving one's self even within the confines of their own home. As of 2008, an estimated 12 million people in the United States reported at least some mobility difficulty. Many of these individuals include senior citizens, whose population is ever drastically increasing as "baby boomers" begin to enter their later stages of life.

There exist in the prior art numerous examples of ambulatory devices such as walking canes, walking sticks, crutches and the like which aid in providing stability to persons requiring assistance when walking or standing. Generally, though, conventional walking canes contain a fixed design which imposes excessive stress on the user's hands, wrists and triceps, resulting in associated shoulder and back strain caused by gait compensation. Conventional cane shafts also have the deleterious effect of providing stiff repetitive shock to hands and arms as weight is applied to the cane, resulting in painful fatigue through frequent use. Such strains may be exacerbated by the repetitive motion necessary to walk even short distances, as well as the associated impact stresses transmitted through the cane and to the user when engaging the tip with the ground.

There presently exists a need in providing a durable walking cane to overcome the aforementioned obstacles. Such a walking aid would diminish excessive stress applied to the hands and wrists during its use, thereby decreasing gait compensation to reduce the occurrence of shoulder and back strain. An object of the present invention would therefore include providing a light-weight cane having an improved shaft and handle construction to achieve the aforementioned goals.

BRIEF SUMMARY OF INVENTION

The present invention overcomes the deficiencies of the prior art in several of its embodiments. It is therefore an object of the present invention to provide a walking cane or crutch including a non-stationary, shock absorbing handle assembly to assist in relieving hand, wrist and arm strains. In one embodiment, the handle assembly comprises a closed configuration having opposing first and second upright posts. The posts carry a grip biased by first and second pliable mounts held in place under tension by a fastening mechanism. The mounts act as shock absorbers and permit the grip to have limited omni-directional movement relative to each post.

In another embodiment, the handle assembly comprises an open configuration having a generally upright post, a grip connectable substantially orthogonal to the post, and a pliable

2

mount engageable with the post and the grip. A fastening mechanism secures the grip and the mount to the post, thereby biasing mount against the grip. The mount acts as a shock absorber and permits the grip to have limited omni-directional movement relative to the post.

In another embodiment, a pliable mount is positioned between the handle assembly and a vertical support. The mount acts as shock absorbers and permits the handle assembly to have limited omni-directional movement relative to the vertical support.

It is also an object of the present invention to provide a walking cane having a tilting handle assembly so that the handle assembly can be adjusted to produce ergonomically optimized loading positions for the hand and wrist, even on an individualized need. In one embodiment, the handle assembly is selectively positionable relative to a vertical support by providing first and second shims cooperably engaged with another. The shims are preferably positioned between the handle assembly and the vertical support. The orientation of the handle assembly relative to the vertical support can be modified by selectively positioning either shim relative to the other.

Another object of the present invention is to provide an extremely lightweight vertical support, durable enough to withstand the force of a person resting, leaning or using the cane as a means of support. In one embodiment, the vertical support includes three parallel elongated rods spaced apart from one another in a triangular position. Triangular brackets attach to the rods to prevent flexation thereof when a load is applied to the walking device.

BRIEF DESCRIPTION OF THE DRAWINGS

FIG. 1 is perspective view of a first embodiment of a walking cane of the present invention.

FIG. 2 is a perspective view of a vertical support for use in the walking cane of the present invention.

FIG. 3 is a perspective view of a handle assembly in accordance with the first embodiment of the present invention.

FIG. 4 is an exploded view of the handle assembly in accordance with the first embodiment of the present invention.

FIG. 5 is a cross-sectional view of the handle assembly in accordance with the first embodiment of the present invention as taken along lines A-A in FIG. 3.

FIG. 6 is a perspective view of a shim as used in accordance with a neck assembly of the present invention.

FIGS. 7a, 7b and 7c illustrate selected orientations of the handle assembly in accordance with the present invention.

FIG. 8 is a perspective view of a second embodiment of the walking cane of the present invention.

FIG. 9 is a perspective view of a handle assembly in accordance with the second embodiment of the present invention.

FIG. 10 is an exploded view of the handle assembly in accordance with the second embodiment of the present invention.

FIG. 11 is a cross-sectional view of the handle assembly in accordance with the second embodiment of the present invention as taken along lines B-B in FIG. 9.

FIG. 12 is a perspective view of an alternative embodiment of the walking cane in accordance with the present invention.

FIG. 13 is an exploded view of a handle assembly in accordance with the alternative embodiment of the present invention.

FIG. 14 is an exploded view of an alternative handle assembly in accordance with the alternative embodiment of the present invention.

DETAILED DESCRIPTION

A first embodiment of a walking cane according to the present invention is generally indicated at 20 in FIG. 1. While the present description uses the term cane throughout, it should be noted that that term is meant to include a multiplicity of walking aids or ambulatory devices, including crutches and walkers. The walking cane 20 generally includes a handle assembly 22 and a ground engaging assembly 24, each connected to a vertical support assembly 26. As illustrated in FIG. 2, the vertical support assembly 26 includes three elongated rods 28 spaced-apart in a preferably triangular fashion. Each rod 28 is preferably constructed from a light-weight, high tensile strength material, for example carbon fiber composite. However, similar suitable materials for the construction of the rods 28 are well within the scope of the present invention, including aluminum, magnesium, titanium, advanced high-strength steels, fiber-reinforced composites, and metal matrix composites. It has been discovered that by replacing the single shaft support of the prior art with three spaced-apart rods 28 placed in triangular formation, ease of maneuverability is greatly improved and the overall weight of the cane 20 is reduced while maintaining, if not improving, the overall structural integrity of the cane 20. It should be noted, though, that it is well within the scope of the present invention to include additional rods 28 in other formations, including a square formation, pentagonal, hexagonal, heptagonal, octagonal formations as well. It is also within the scope of the present invention to provide hollow tubes instead of solid rods. The rods 28 are held in fixed relation to one another by a series of stabilizing brackets 30. Each bracket 30 includes a generally triangular configuration having an aperture 32 positioned at each vertex. These apertures 32 are sized for receiving each rod 28 so that the brackets 30 may be permitted to be positionable along the length of support assembly 26 during the construction thereof, but at the same time providing a snug fit such that the bracket 30 can be retained at any selected position. After proper positioning, each bracket 30 can be adhered into place, for example with the application of an adhesive. As illustrated in FIG. 2, three brackets 30 are utilized to retain the rods 28 in fixed relation to one another. It should be noted, though, that it is well within the scope of the present invention to provide additional brackets 30, and also that as few as a single bracket 30 may be provided. Each bracket 30 is preferably of unitary construction, molded from suitable plastic, metal, or composite material, such as carbon fiber or Delrin® as made commercially available by E.I. Du Pont de Nemours and Company of Wilmington, Del., as is known in the art.

As illustrated in FIGS. 3 and 4, the handle assembly 22 includes a base 34 having opposing substantially upright posts 36 for supporting a grip assembly 38. By substantially upright it is meant that the posts 36 extend generally perpendicularly upward from the lengthwise plane of the base 34, but may deviate therefrom up to 90 degrees in either direction and still be within the scope of the present invention. The base 34 and posts 36 are preferably of unitary construction, but it is well within the scope of the present invention to attach the posts 36 to the base 34 as separate pieces. It is also within the scope of the present invention to provide the base 34 and posts 36 in two separate halves which are joined together at a center portion of the base 34. The base 34 and posts 36 are preferably molded from plastic or other suitable composite material

which provides for lightweight and durable support, such as Delrin® as made commercially available by E.I. Du Pont de Nemours and Company of Wilmington, Del. Again, the use of any lightweight, high-strength material is well within the scope of the present invention, including aluminum, magnesium, titanium, advanced high-strength steels, fiber-reinforced composites, and metal matrix composites.

The grip assembly 38 includes a cross member 40 adapted to contain a grip 42. The cross member 40, which is generally cylindrical in shape, preferably includes a layer of composite plastic 44 molded over an inner metallic shaft 46. Terminal ends 48 of the shaft 46 extend beyond the molded layer 44 for supporting pliable mounts or dampeners 50. The mounts 50 are configured to receive the respective terminal end 48 within a recessed cavity 52. Each recessed cavity 52 may include a corresponding shape, in this example hexagonal, to receive the respective terminal end 48 in a specific orientation. It should be noted, though, that alternate shapes of each terminal end 48, and of the corresponding cavity 52 of the mount 50, are within the scope of the present invention and include, but are not limited to, circular, oval, square, pentagonal, heptagonal and octagonal configurations. An opposing frusto-conical or semi-spherical portion 54 of each mount 50 seats within a corresponding cavity 56 contained within each upright post 36, which facilitates in securing the grip assembly 38 to the base 34.

The grip 42, preferably constructed from a pliant material such as silicone, includes an inner core 58 disposable over the molded layer 44 for attachment to the cross member 40. The grip 42 may optionally contain a layer of memory foam (not shown) to enhance the comfort thereof when grasped by a user. The grip 42 also contains a webbing support 60 partially extending from an outer surface. To increase comfort, the webbing support 60 is designed to accept a portion of a user's palm, thumb, and the heel and webbing of the hand, to provide greater load-bearing surface area to reduce pressure applied to the user's hand. The webbing support 60 may be configured for a left-handed user, as illustrated in FIG. 3, or a right-handed user, as illustrated in FIG. 4. The webbing support can also be selectively positioned for use with both left-handed and right-handed users.

To secure the grip assembly 38 to the base 34, each post 36 contains an aperture 62 for receiving a male threaded fastener 64 therethrough. Each mount 50 contains a corresponding aperture 66 for receiving the fastener 64, and each terminal end 48 of the cross member 40 contains a female threaded internal bore 68. Upon disposing the fastener 64 through the respective post 36 and mount 50, the fastener 64 threadably engages with the corresponding terminal end 48 of the shaft 46. Upon further tightening the fastener 64, each mount 50 seating within the respective post cavity 56 compresses under tension, frictionally engaging the grip assembly 38 to the posts 36 while at the same time allowing limited omni-directional movement of the grip assembly 38 relative to the base 34 and posts 36. By omni-directional it is meant that the grip assembly 38 is permitted limited movement within six degrees of freedom, including heaving, swaying, surging, pitching, yawning and rolling.

As illustrated in FIG. 5, to permit the omni-directional movement of the grip assembly 38, the length of the cross member 40 is slightly less than the distance between the posts 36 while under tension, providing a gap 69 between the cross member 40 and the inner surface of each post 36. Also, to prevent excess torsional movement of the grip assembly 38 when excessive torsional force is applied to the webbing support 60, each post 36 may contain an optional ledge 70 positioned on an inner surface thereof which engages a cor-

5

responding outcropping **72** contained on the cross member **40**. The pliant mounts **50** allow the grip assembly **38** a limited range of movement relative to the base **34**, including translational movement in a three-dimensional plane, as well as pivotal pitch, roll and yaw movement. The mounts **50** further act as shock reducers, absorbing both impact stresses transmitted through the cane **20** from contact with the ground, as well as movement applied to the handle assembly **22** by the user.

Connecting the handle assembly **22** to the support assembly **26** is accomplished by means of a neck assembly **76**. The neck assembly **76** includes a circular mounting cap **78** which is positionable over and attached to the upper portion **80** of the support assembly **26**, wherein a top bracket **30** and the rods **28** preferably seat therein and are adhered to the cap **78**. Alternatively, the cap **78** can be configured to have separate apertures (not shown) for receiving the upper terminal end of each rod **28** which are journaled therein. The mounting cap **78** contains a centrally located female threaded aperture **82** for receiving a male threaded fastener **84**. The fastener **84** is disposable through an aperture **86** located in the central portion of the base **34** to threadably engage the cap **78**, thereby securing the handle assembly **22** to the support assembly **26**. The cap **78** may be constructed of a pliant material which further acts as a shock absorber, reducing or eliminating impact stresses transmitted through the tip assembly **24** and support assembly **26** to the handle assembly **22** from contact with the ground.

The neck assembly **76** may further include mateable shims **88** which allow for the selectively angled positioning of the handle assembly **22** relative to the support assembly **26**. As illustrated in FIG. **6**, an exemplary shim **88** contains a central bore **90** for disposing the fastener **84** therethrough. Each shim **88** also contains a first angled surface **92** on one side, and a level surface **93** on the opposing side. The shims **88** are engaged with one another, preferably such that the angled surfaces **92** contact each other. As illustrated in FIGS. **7a**, **7b** and **7c**, the shims **88** can be rotated relative to one another such that the pitch and roll of the handle assembly **22** relative to the support assembly **26** can be selectively positioned. Such adjustment may be especially desirable if the user has some malady which makes it difficult in grasping a cane in a conventional fashion. As illustrated in FIG. **7a**, the shims **88** are adjusted so that the grip assembly **38** is a substantially parallel with the ground when the cane **20** is in an upright position. As illustrated in FIG. **7b**, the top shim **88** has been positioned to adjust the pitch and roll of the handle assembly **22** relative to the support assembly **26**. As illustrated in FIG. **7c**, both shims **88** have been positioned to adjust the pitch and roll of the handle assembly **22** relative to the support assembly **26**.

Referring back to FIG. **1**, a bottom portion **94** of the support assembly **26** connects to the ground engaging assembly **24**. The ground engaging assembly **24** generally includes a foot pad **95** connected to a threaded rod **96**. The rod **96** disposes within a housing **97** attached to the support assembly **26** and containing a threaded burr (not shown). By rotating the threaded rod **96**, the overall length of the cane **20** be adjusted. The bracket **30** includes a central aperture **98** so that the threaded rod **96** can be disposed therethrough. This allows the bracket **30** to be positioned to stabilize the lower portion **94** of the support assembly **26** without interfering with the ground engaging assembly **24**. Those skilled in the art should recognize that other known ground engaging assemblies can be employed with the present invention, including fixed length assemblies, locking assemblies and the like.

In initially setting up the walking cane **20** for a specific user, the user can customize the cane **20** by adjusting its

6

height (if the ability to do so is available), as well as adjust the pitch and yaw of the handle assembly **22** by loosening the fastener **84** and selectively positioning the shims **88**. Upon attaining the desired position of the handle assembly **22**, the fastener **84** is tightened to lock the handle assembly **22** in place. Selective rotational positioning of the handle assembly **22** can also be accomplished in this manner if a directional foot is used.

Referring now to FIGS. **8**, **9** and **10**, a second embodiment of a walking cane of the present invention is indicated at **100**. The second embodiment **100** contains all the features of the first embodiment **20**, with the exception that a handle assembly **102** now employs an open design. As such, like references in the description of the second embodiment correspond with similar parts of the first embodiment. As illustrated in FIGS. **9**, **10** and **11**, the handle assembly **102** includes a base **104** having a substantially upright post **106** for supporting a grip assembly **108**. By substantially upright it is meant that the post **106** extends generally perpendicularly upward from the lengthwise plane of the base **104**, but may deviate therefrom up to 90 degrees in either direction and still be within the scope of the present invention. The base **104** and post **106** are preferably of unitary construction, but it is well within the scope of the present invention to attach the post **106** to the base **104** as separate pieces. The base **104** and post **106** are preferably molded from plastic or other suitable composite material which provides for lightweight and durable support, such as Delrin® as made commercially available by E.I. Du Pont de Nemours and Company of Wilmington, Del. Again, the use of any lightweight, high-strength material is well within the scope of the present invention, including aluminum, magnesium, titanium, advanced high-strength steels, fiber-reinforced composites, and metal matrix composites.

The grip assembly **108** includes a cantilevered member **110** adapted to contain a grip **112**. The cantilevered member **110**, which is generally cylindrical in shape, preferably includes a layer of composite plastic **114** molded over an inner metallic shaft **116**. A proximal end **118** of the shaft **116** extends beyond the molded layer **114** for supporting a pliable mount or dampener **120**. The mount **120** is configured to receive the proximal end **118** within a recessed cavity **122**. The recessed cavity **122** may include a corresponding shape, in this example hexagonal, to receive the proximal end **118** in a specific orientation. It should be noted, though, that alternate shapes of the proximal end **118**, and of the corresponding cavity **122**, are within the scope of the present invention and include, but are not limited to, circular, oval, square, pentagonal, heptagonal and octagonal configurations. An opposing frusto-conical or semi-spherical portion **124** of the mount **120** seats within a cavity **126** contained within the upright post **106**, which facilitates in securing the grip assembly **108** to the base **104**.

The grip **112**, preferably constructed from a pliant material such as silicone, includes an inner core **130** disposable over the molded layer **114** for attachment to the cantilevered member **110**. The grip **112** may also contain a layer of memory foam (note shown) to enhance the comfort thereof when grasped by a user. The grip **112** also contains a webbing support **132** partially extending from an outer surface. To increase comfort, the webbing support **132** is designed to accept a portion of a user's palm and thumb, and the webbing of the hand therebetween, to provide greater load-bearing surface area to reduce pressure applied to the user's hand. The webbing support **132** may be configured for a left-handed user, as illustrated in FIGS. **8** and **10**, or a right-handed user,

as illustrated in FIG. 9. The webbing support 132 can also be selectively positioned for use with both left-handed and right-handed users.

To secure the grip assembly 108 to the base 104, the post 106 contains an aperture 134 for receiving a male threaded fastener 136 therethrough. The mount 120 also contains a corresponding aperture 138 for receiving the fastener 136, and the proximal end 118 contains a female threaded internal bore 140. Upon disposing the fastener 136 through the post 106 and mount 120, the fastener 136 threadably engages with the proximal end 118 of the shaft 116. Upon further tightening the fastener 136, the mount 120 seats within the post cavity 126 and compresses under tension, frictionally engaging the grip assembly 108 to the post 106, while at the same time allowing limited omni-directional movement of the grip assembly 108. By omni-directional it is meant that the grip assembly is permitted limited move within six degrees of freedom, including heaving, swaying, surging, pitching, yawing and rolling.

To permit the omni-directional movement of the grip assembly 108, a small gap 141 exists between the cantilevered member 110 and the inner surface of post 106, as best illustrated in FIG. 11. To prevent excess torsional movement of the grip assembly 108 when excessive torsional force is applied to the webbing support 132, the post 106 may contain an optional ledge 142 positioned on an inner surface thereof to receive a corresponding outcropping 144 contained on the cantilevered member 110. The pliant mount 120 allows the grip assembly 108 a limited range of pitch, yaw and roll movement relative to the base. The mount 120 further acts as a shock reducer, absorbing both impact stresses transmitted through the cane from contact with the ground, as well as movement applied to the handle assembly 102 by the user.

Similar to the first embodiment 20, the handle assembly 102 connects to the support assembly 26 by means of the neck assembly 76. The handle assembly 102 is therefore positionable relative to the support assembly 26 through use of the shims 88 in the same manner as previously described. However, and as illustrated in FIG. 9, the neck assembly may only consist of the cap member 78.

Turning now to FIG. 12, an alternative embodiment of the walking cane of the present invention is generally depicted at 200. The walking cane 200 includes a handle portion 202 connected to a multi-member shaft portion 204 to which is attached a tip portion 206. The handle portion 202 includes a parabolic saddle-shaped member 208 connected to the shaft portion 204 by a connecting assembly 210. The design of the handle is such that the user's force from when walking is always directed in the most efficient way toward the central support of the shaft. No matter which angle the user uses to orient the cane to the ground while walking, the symmetrical fork-shaped handle directs the physical "load" to the shaft. This eliminates the need for the "offset" angle commonly used in conventional canes to solve this problem. Referring to FIGS. 13 and 14, each end 212, 213 of the saddle member 208 is designed to receive respective terminal ends 214 of a handle 216. Each terminal end 214 of the handle 216 includes a compressible member 218 which seats within the respective end 212, 213 to secure the handle 216 to the saddle member 208. Each compressible member 218 is designed to be slightly positionable relative to the saddle-shaped member 208 in order to permit the handle 216 to adjust its position when a user grips the handle 216 and positions the cane 200 to support the user's weight thereon. As such, regardless the orientation of the cane 200 relative to the ground, the positionability of the handle 216 enables greater relaxation and relief of stress upon the user's hand, wrist, arm and elbow. This

unique anti-shock system utilizes a cylinder or sphere made of compressible foam or silicone materials. A horizontal dowel-type rod 219 structure inside the grip extends beyond the grip into the center of these shock absorbers. Because the dowel from the grip is now surrounded by shock absorbing materials at each end, the shock absorption is omni-directional in that shock protection is afforded no matter which angle the user orients the cane to the ground. Further, the compressibility of each member 218 also absorbs shock forces transferred through the cane 200 during the repetitive engagement and disengagement of the tip portion 206 with the ground while the user is walking with the cane 200.

Moreover, the handle 216 is ergonomically designed to provide an optimized gripping surface to further reduce stresses on the hand, wrist, arm and shoulder to relieve pain and fatigue. In so doing, the ergonomic handle 216 moves the primary point of stress and force from the weak, bony parts of the hand and wrist to the strong, "meaty" parts. The ergonomic handle 216 enables the hand, wrist and arm to be oriented in such a way as to provide maximum strength and minimal strains to the forearm, elbow, back and shoulder. The shape of the handle 216 provides surer, more comfortable gripping area for the thumb and forefinger, and also moves the main stress point away from the bony part of the hand to the meatier palm and heel areas.

The shaft portion 204 includes a plurality of elongated members 220. Each elongated member 220 may consist of a hollow tube, for example a 1/4 inch tube, or a solid rod, for example a 1/8 inch rod. The construction of either the tube or the rod preferably includes a light-weight material exhibiting a high tensile strength. Such suitable materials include, but are not limited to, carbon graphite and aluminum. Preferably three rods 220 are implemented and spaced apart at each terminal end thereof, and at an approximate midsection by a spacer 224. It should be noted, though, that a different number of elongated members 220, or a differing positioning thereof, is well within the scope of the present invention. By providing a plurality of lightweight elongated members 220 exhibiting high tensile strength, the overall weight of the cane 200 is drastically reduced without decreasing, and in some cases increasing, the strength of the cane 200.

Positioned at the terminal end of the shaft portion 204 is the tip portion 206. The tip portion 206 includes a member 226 engageable with the ground connected to a rod or tube 228 slidably disposable between the elongated members 220. A flip-lock 230 secures the tip portion 206 relative to the shaft 204 when the tip 226 is at a desired position. The tip portion 206 is thereby positionable to extend or decrease the overall length of the cane 200 to fit the needs of the respective user.

Although the present invention has been described with reference to preferred embodiments, workers skilled in the art will recognize that changes may be made in form and detail without departing from the spirit and scope of the invention.

The invention claimed is:

1. An ambulatory device comprising:

a handle configured for grasping by a user's hand, the handle comprising:

a first generally upright rigid post;

a shaft with a proximal end connected to the first post, the shaft adaptable for grasping by a user's hand; and

a pliable mount disposed between the proximal end of the shaft and the first post, the first mount engaged with the first post and the shaft, the first mount being biased against the shaft;

a ground engaging member; and

a support portion connecting the handle portion to the ground engaging member, the support portion compris-

9

ing three parallel elongated rods triangularly spaced apart from one another, wherein a first end of each rod connects to the handle portion, wherein a second opposing end of each rod connects to the ground engaging member, and wherein the shaft is permitted omni-directional movement relative to the first post.

2. The device of claim 1 and further comprising a generally triangular bracket containing apertures at each vertex for receiving each of the three rods, the bracket slidably positionable along the length of the rods.

3. The device of claim 2 and further comprising a second triangular bracket containing apertures at each vertex for receiving each of the three rods, the second bracket slidably positionable along the length of the rods.

4. An ambulatory device comprising:

a handle configured for grasping by a user's hand;

a ground engaging member;

a support portion connecting the handle portion to the ground engaging member, the support portion comprising three parallel elongated rods wherein a first end of each rod connects to the handle portion, and wherein a second opposing end of each rod connects to the ground engaging member; and

a neck assembly connecting the handle to the support portion, the neck assembly comprising:

a first shim connected to the support portion; and

a second shim cooperably engaged with the first shim, the second shim connected to a lower portion of the handle, wherein the orientation of the handle relative to the support portion can be modified by selectively positioning either shim relative to the other.

5. The device of claim 4 wherein the handle comprises:

a first generally upright rigid post;

a shaft having a proximal end connected to the first post, the shaft adaptable for grasping by a user's hand;

a first pliable mount disposed between the proximal end of the shaft and the first post, the first mount engaged with the first post and the shaft, wherein the first mount permits omni-directional movement of the shaft relative to the first post to assist in relieving hand, wrist and arm strains and reduce impact stress when the user grasps the handle assembly in using the walking aid.

6. The device of claim 5 wherein the handle further comprises a fastener to secure the shaft and mount to the post, the post and the mount each including surfaces defining an aperture therethrough, the shaft including a bore for receiving a terminal end of the fastener, the terminal end of the fastener disposable through the aperture of the post and the aperture of the mount to engage the bore of the shaft, whereupon the shaft is urged against the mount.

7. An apparatus to assist a user in walking, the apparatus comprising;

a handle assembly;

a support assembly having an upper portion connected to the handle assembly, the support assembly including three parallel members spaced apart from one another in triangular fashion;

a foot member connected to a lower portion of the support assembly, the foot member engageable with the ground; and

a neck assembly connecting the handle assembly to the support assembly, the neck assembly including a first shim connected to the support assembly, and a second shim engaged with the first shim and connected to a lower portion of the handle assembly, wherein the orientation of the handle assembly relative to the support

10

assembly can be modified by selectively positioning either shim relative to the other.

8. The apparatus of claim 7 and further comprising a pliant cap positioned between an upper portion of the support assembly and a lower portion of the handle assembly, the pliant cap for reducing vibrations in the handle assembly by absorbing impact energy propagated through the support assembly by the impact of the foot member with the ground.

9. The apparatus of claim 7 wherein the handle assembly comprises:

a first generally upright rigid post;

a shaft with a proximal end connected to the first post, the shaft adaptable for grasping by a user's hand; and

a first pliable mount disposed between the proximal end of the shaft and the first post, the first mount engaged with the first post and the shaft, the first mount being biased against the shaft, wherein the shaft is permitted omni-directional movement relative to the first post.

10. The apparatus of claim 9 wherein the handle assembly further comprises:

a second generally upright rigid post positioned in cooperable relation to the first post, a distal end of the shaft connected to the second post; and

a second pliable mount disposed between the distal end of the shaft and the second post, the second mount engaged with the second post and the terminal end of the shaft, wherein the second mount biases against the distal end of the shaft while permitting omni-directional movement of the distal end of the shaft relative to the second post to reduce impact stress and increase user comfort when the user grasps the handle assembly in using the apparatus.

11. The apparatus of claim 9 and further comprising a pliant cap positioned between an upper portion of the support assembly and the handle assembly, the cap reducing impact energy propagated through the support assembly by the impact of the foot member with the ground.

12. The apparatus of claim 9 and further comprising a neck assembly connecting the handle assembly to the support assembly, the neck assembly including a first shim connected to an upper portion of the support assembly, and a second shim engaged with the first shim and connected to a lower portion of the handle assembly, wherein the orientation of the handle assembly relative to the support assembly can be modified by selectively positioning either shim relative to the other.

13. The apparatus of claim 12 and further comprising a pliant cap positioned between the upper portion of the support assembly and the lower portion of the handle assembly, the cap reducing vibrations in the handle assembly by absorbing impact energy propagated through the support assembly by the impact of the foot member with the ground.

14. A walking cane having a handle and a ground engaging member connected by an elongated shaft, the shaft comprising three parallel members positioned in triangular formation, the handle comprising:

a first generally upright rigid post;

a second shaft with a proximal end connected to the first post, the second shaft adaptable for grasping by a user's hand; and

a pliable mount disposed between the proximal end of the second shaft and the first post, the first mount engaged with the first post and the second shaft, the first mount being biased against the second shaft, wherein the second shaft is permitted omni-directional movement relative to the first post.

11

15. The device of claim **14** wherein the parallel members are spaced apart from one another.

16. The apparatus of claim **14** and further comprising a neck assembly connecting the handle to the elongated shaft, the neck assembly including a first shim connected to an upper portion of the elongated shaft, and a second shim

12

engaged with the first shim and connected to a lower portion of the handle, wherein the orientation of the handle relative to the elongated shaft can be modified by selectively positioning either shim relative to the other.

* * * * *